

Benutzerhandbuch
Manuel de l'utilisateur
Manuale per l'utente
Manual de uso
User handbook

Remote Lock
Remote Lock
Remote Lock
Remote Lock
Remote Lock

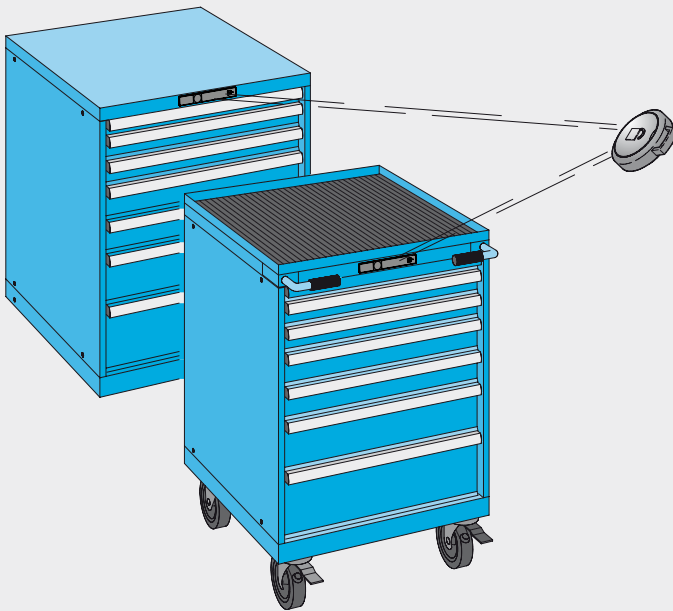

Inhaltsverzeichnis

Sommaire

Sommario

Índice

Table of contents

Warnhinweise Attention Avvertenze Precaución Warning notices	3	Kontrolle Contrôle Controllo Verificación Check	17
Informationen Informations Informazioni Información Information	7	Endkontrolle Contrôle final Controllo finale Verificación final Final check	18
Ausbau Schloss-System Démontage du système de fermeture Smontaggio del sistema di chiusura Desmontaje del sistema de cierre Locking system dismantling	9		
Stromanschluss Raccordement électrique Collegamento alla rete elettrica Conexión eléctrica Power connector	10		
Mobil aufladen Chargement mobile Caricamento mobile Recarga móvil Mobile recharge	11		
Ladevorgang Mobil Chargement mobile en cours Caricamento mobile in corso Operación de recarga móvil Mobile recharging	12		
Verkettung Liaison Concatenamento Interconexión Chaining	14		
Automatische Schliessung Fermeture automatique Chiusura automatica Cierre automático Automatic locking	16		

Warnhinweise
Attention
Avvertenze
Precaución
Warning notices



Warnhinweise
Attention
Attenzione
Precaución
Warning notices



Beachten / Befolgen
Respecter / Suivre
Considerare / Seguire
Observer / Para seguir
To observe / To follow



ENTSORGUNG
ELIMINATION
SMALTIMENTO
ELIMINACIÓN
DISPOSAL



Informationen
Informations
Informazioni
Información
Information



Montageanleitung
Instruction de montage
Istruzioni per il montaggio
Instrucción de montaje
Assembly instructions

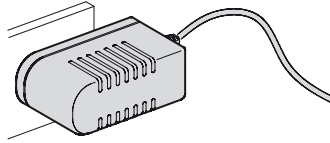

ONLY ORIGINAL

making workspace work

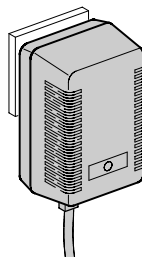
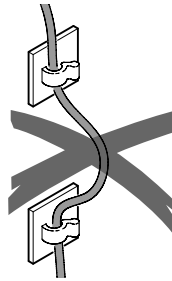
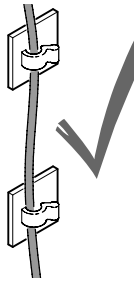
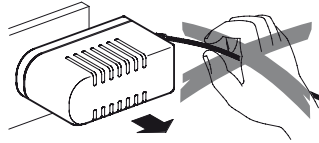

ONLY ORIGINAL

making workspace work



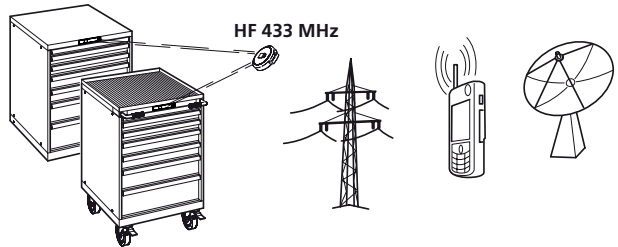

Die Funktion des E-lock-Handfunksenders kann durch andere elektrische Apparate oder Anlagen beeinträchtigt werden.

La fonction de l'émetteur radio manuel e-lock peut être perturbée par d'autres appareils ou installations électriques.

Il funzionamento del radiotrasmettitore portatile e-lock può essere disturbato da altri apparecchi o impianti elettrici.

El funcionamiento del radiotransmisor Remote Lock puede sufrir interferencias debido a otros aparatos o equipos electrónicos.

The function of the e-lock remote control unit may be disturbed by other electrical devices or equipment.

Warnhinweise
Attention
Avvertenze
Precaución
Warning notices

Bleiakku, 12 V, 1,2 Ah, Ladezeit 8 h
Accu de plomb, 12 V, 1,2 Ah, durée de charge 8 h
Accumulatore al piombo, 12 V, 1,2 Ah, tempo di carica 8 h
Batería de plomo, 12 V, 1,2 Ah, tiempo de carga 8 h
Lead-acid battery, 12 V/1.2 Ah, charging time 8 h

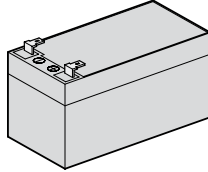

ONLY ORIGINAL
 LISTA
making workspace work

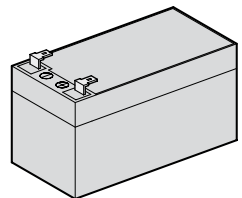
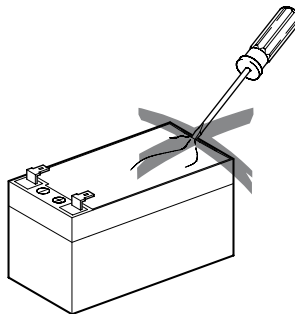
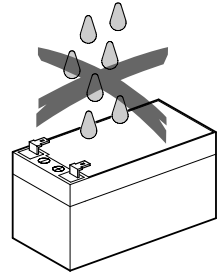
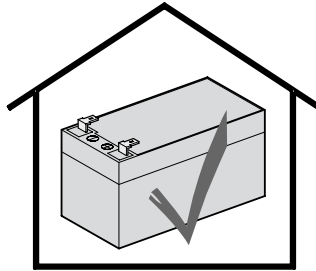

Die nachfolgende Montage- und Bedienungsanleitung ist als Sicherheitsmassnahme zwingend zu befolgen. Sie ist sämtlichen Beschäftigten zur Kenntnis zu bringen und von diesen zu beachten!

Les instructions suivantes de montage et d'utilisation doivent impérativement être appliquées comme mesures de sécurité. Elles doivent être portées à la connaissance de tous les collaborateurs et respectées de ceux-ci!

Le seguenti istruzioni per il montaggio e l'utilizzazione devono imperativamente essere rispettate per poter garantire le misure di sicurezza. L'intero personale ne deve essere a conoscenza e le deve rispettare!

Como medida de seguridad, es imprescindible seguir las instrucciones del presente manual de instalación y uso. ¡Todos los operarios deberán conocerlas y respetarlas!

The following mounting and operating instructions must be observed for safety. All employees should be informed about them and observe them!

Ausbau Schloss-System
Démontage du système de fermeture
Smontaggio del sistema di chiusura
Desmontaje del sistema de cierre
Locking system dismantling

Installation
Mise en place
Collocazione
Instalación
Set up

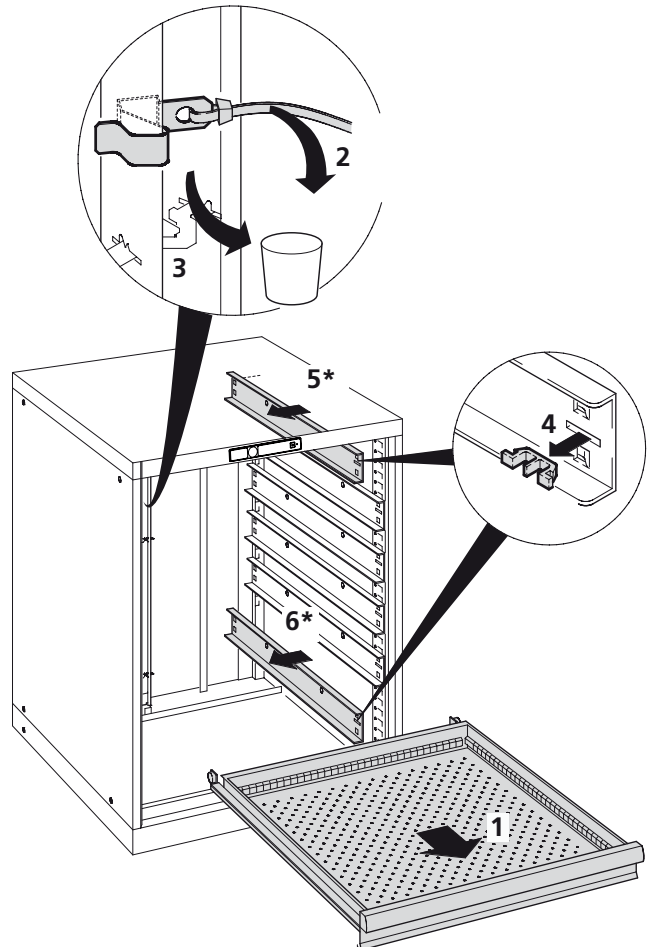

- * nur bei verketteten Schränken notwendig!
- * nécessaire seulement pour des armoires reliées!
- * necessario solo per armadi collegati!
- * ¡necesario sólo para armarios interconectados!
- * necessary only for linked cabinets!

Stromanschluss
Raccordement électrique
Collegamento alla rete elettrica
Conexión eléctrica
Power connector

**Schublade nach Programmierung
einschieben**

**Remettre tiroir après program-
mation**

**Infilare il cassetto dopo la
programmazione**

**Introducir el cajón según
programación**

**Insert drawers after program-
ming**

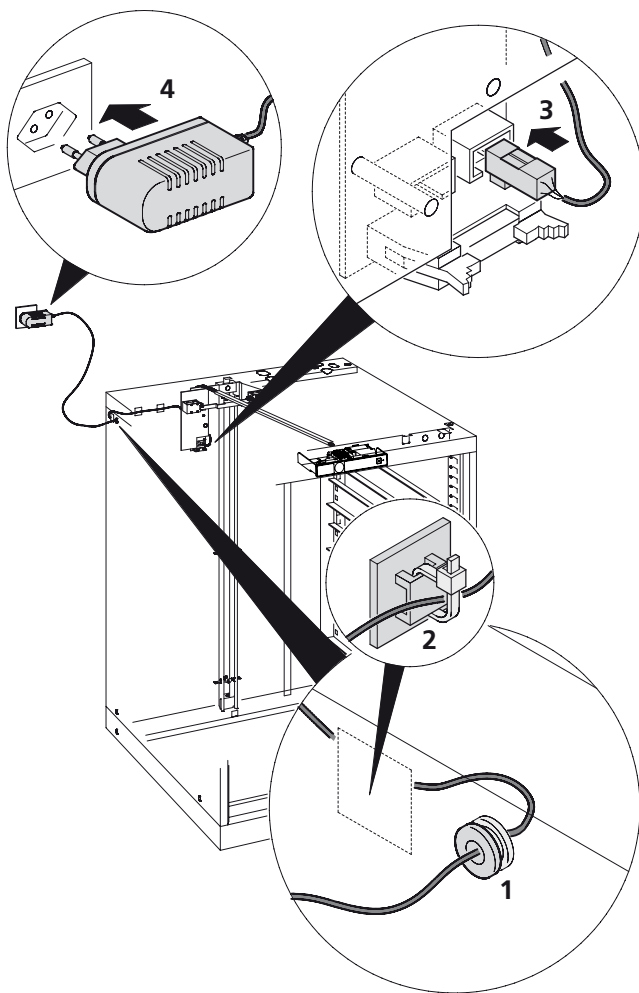

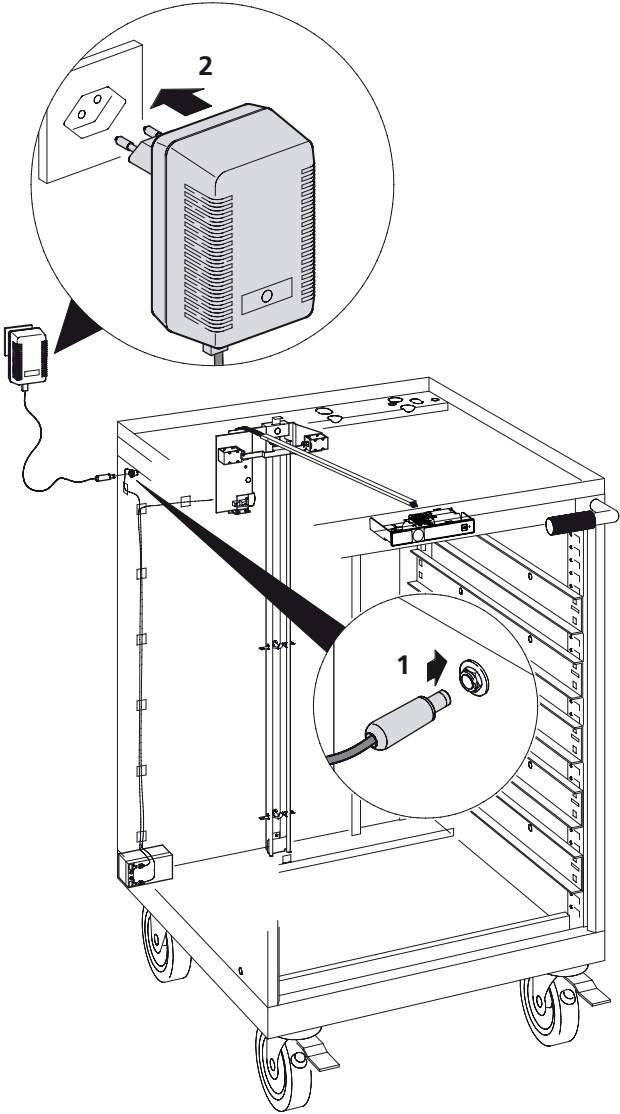

Ladevorgang Mobil
 Chargement mobile en cours
 Caricamento mobile in corso
 Operación de recarga móvil
 Mobile recharging

Normalbetrieb mit geladenem Akku

Fonctionnement normal avec batteries chargées

Funzionamento normale con batteria carica

Modo normal con la batería cargada

Normal operation with charged battery

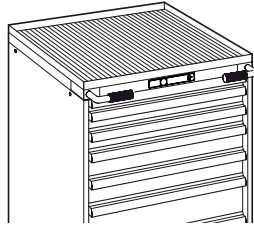

Wenn während 2 Std. kein Gebrauch, Schlafmodus
 Au bout de 2 heures sans utilisation – passage au mode veille
 Se non viene utilizzato per 2 ore, passa alla modalità stand-by
 En caso de inactividad durante 2 horas, pasa a modo stand-by
 Switches into sleep mode after 2 hours without activity

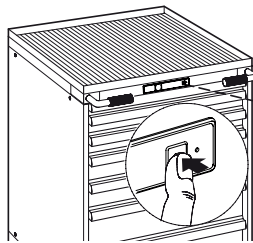

= Betriebsbereit
 = En état de fonctionnement
 = Pronto all'uso
 = Operativo
 = Ready



Bei entladem Akku

En cas de batteries vides

In caso di batteria scarica

Con la batería descargada

When battery is empty



Warnton alle 17 s während 1 min
 Signal d'avertissement retentit toutes les 17 sec, pendant 1 min
 Segnale acustico ogni 17 s per 1 min
 Señal acústica de advertencia cada 17 s durante 1 min
 Beeps every 17 s for 1 min

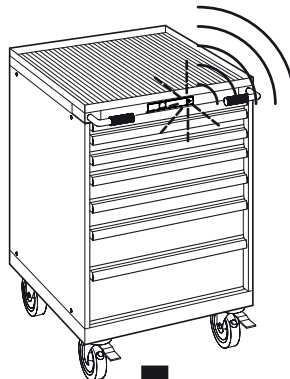

LED blinkt während 1 min
 DEL clignote pendant 1 min
 Il LED lampeggia per 1 min
 El LED parpadea durante 1 min
 LED blinks for 1 min



Ladevorgang Mobil
 Chargement mobile en cours
 Caricamento mobile in corso
 Operación de recarga móvil
 Mobile recharging

Akku laden
 Chargement de batterie
 Caricare la batteria
 Recarga de la batería
 Battery charge



beepbeep!

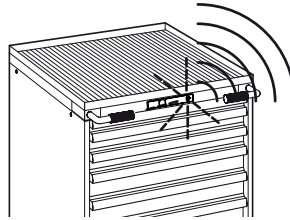

Nach 3 min 15 s Dauerton
 Un bip de 15 sec retentit au bout de 3 min.
 Dopo 3 min segnale continuo per 15 sec
 Después de 3 min 15 s señal acústica permanente
 Sustained beep after 3 min 15 s

LED blinkt
 DEL clignote
 Il LED lampeggia
 El LED parpadea
 LED blinks

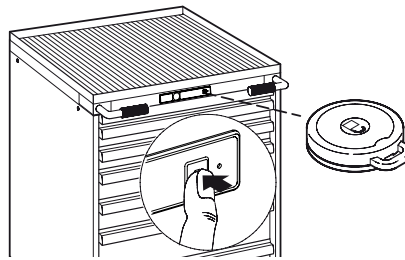

Öffnen nicht mehr möglich
 Ouvrir n'est plus possible
 Apertura non è più possibile
 Ya no es posible abrirlo
 Cannot be opened

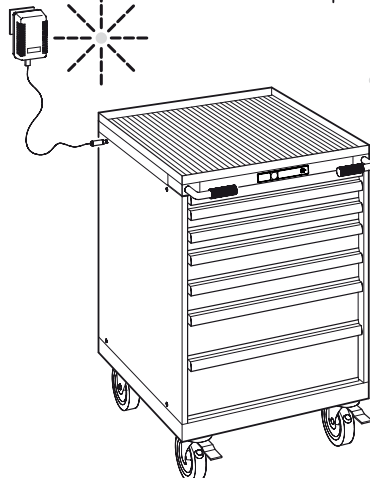
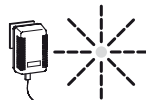

LED leuchtet = Ladevorgang
 DEL est allumée = chargement en cours
 LED acceso = ricarica in corso
 LED encendidos = cargando
 LED lit up = recharging

- Kein leuchten = Ladevorgang beendet
 DEL n'est pas allumée = chargement est terminé
 LED spento = ricarica terminata
 LED apagados = carga finalizada
 LED not lit = battery is recharging

Ladezeit ca.
 Temps de chargement env.
 Tempo di ricarica circa
 Tiempo de carga aprox.
 Recharge time approx.

8 h



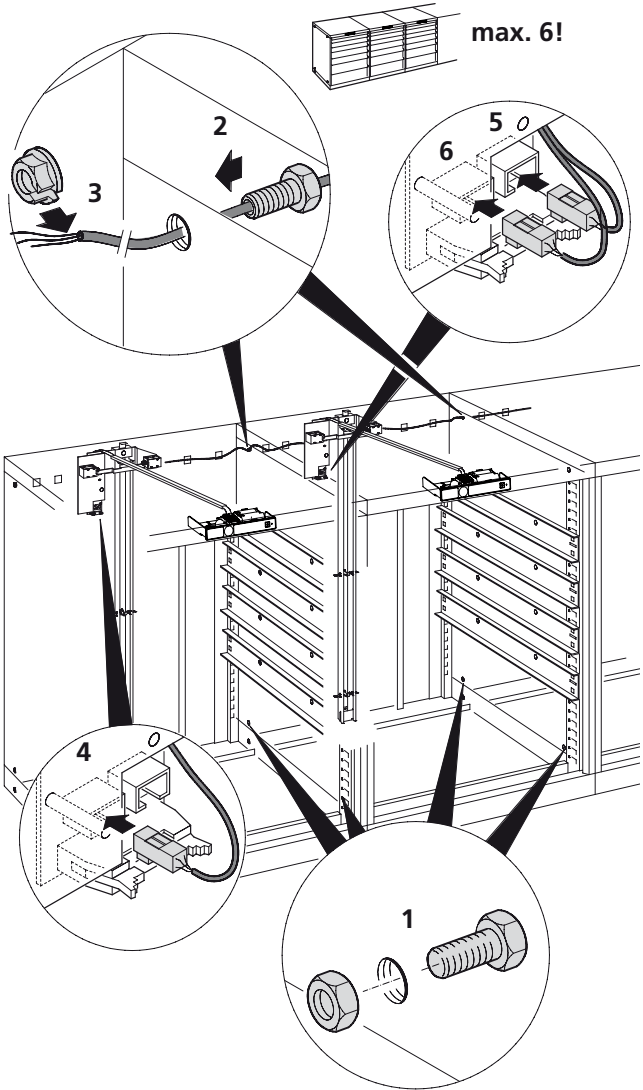



Bei automatischer Schliessung muss bei allen Schränken die gleiche Schliesszeit eingestellt sein!

En cas de fermeture automatique, les mêmes temps de fermeture doivent être réglés sur toutes les armoires!

Se si utilizza la chiusura automatica tutti gli armadi devono avere impostati gli stessi orari di chiusura!

¡Con el cierre automático es imprescindible que todos los armarios estén ajustados con los mismos horarios de cierre!

With automatic locking, all cabinets must have the same locking delay setting!

Schrank programmieren!
Programmer l'armoire!
Programmare l'armadio!
¡Programar el armario!
Program cabinet!

11

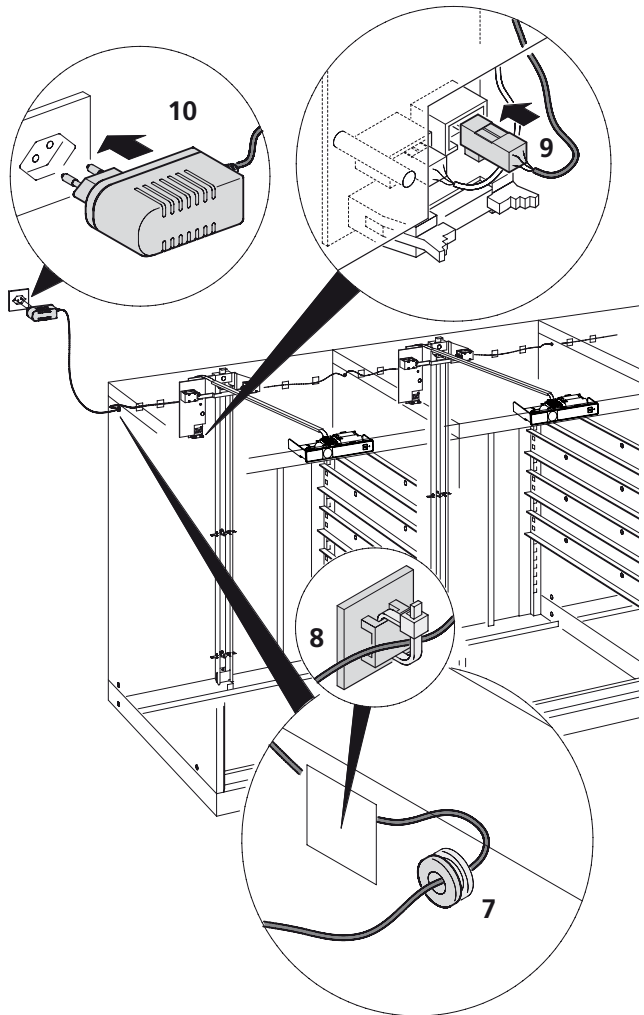

Automatische Schliessung
 Fermeture automatique
 Chiusura automatica
 Cierre automático
 Automatic locking



SHORT: Schrank schliesst automatisch nach ca. 6 s
SHORT: L'armoire se ferme automatiquement au bout d'env. 6 s
SHORT: L'armadio si chiude automaticamente dopo ca. 6 sec
SHORT: el armario se cierra automáticamente a los 6 s aprox.
SHORT: Cabinet automatically locks after approx. 6 s

NO FUNC.: Nicht zulässiger Einstellbereich → vermeiden.
NO FUNC.: Valeur de réglage non admise → éviter.
NO FUNC.: Il range impostazione non consentito → evitare.
NO FUNC.: margen de ajuste no permitido → evítelo.
NO FUNC.: Avoid improper adjustment → range.

OFF: 1x geöffnet, bleibt der Schrank entriegelt, bis die manuelle Schliessung betätigt wird.
OFF: Une fois ouverte, l'armoire reste déverrouillée jusqu'à ce que la fermeture manuelle soit actionnée.
OFF: Una volta aperto l'armadio resta sbloccato finché non viene azionata la chiusura manuale.
OFF: una vez abierto, el armario permanece desbloqueado hasta que se accione el cierre manual.
OFF: Once opened, the cabinet remains unlocked until manual locking is activated.

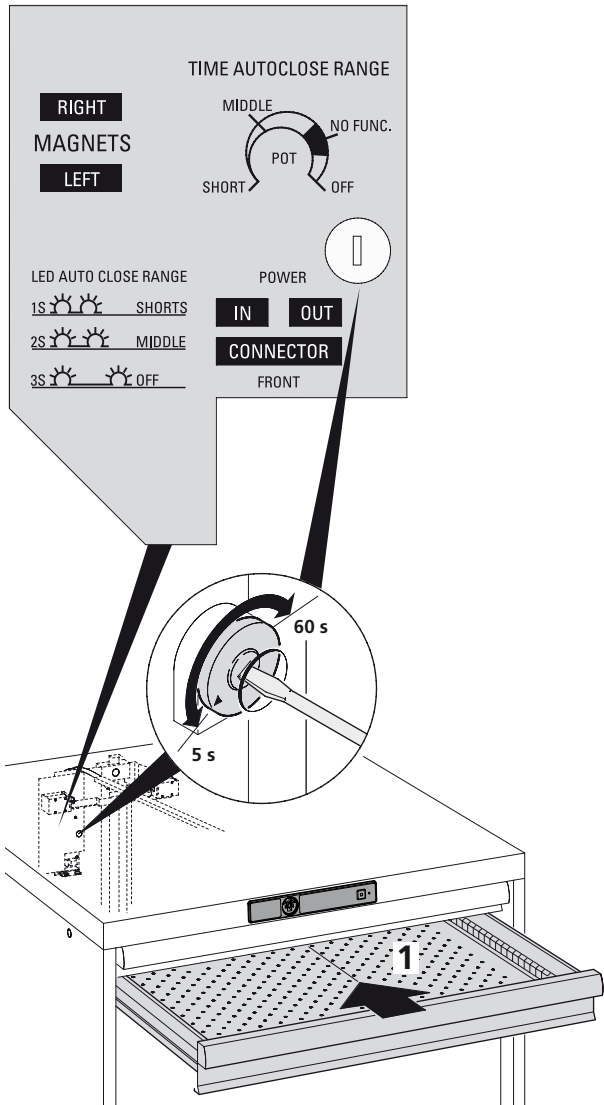

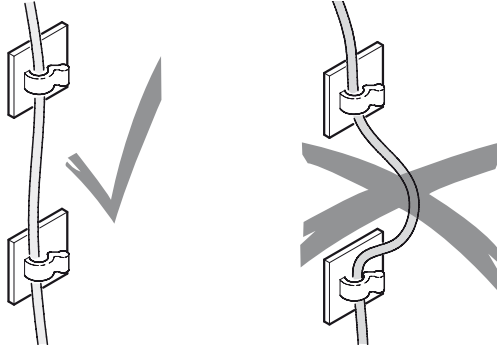

Kabel schlaufenfrei verlegen!
Disposition des câbles exempte de boucles!
Riporre il cavo in modo diritto!
¡Colocar el cable procurando que no quede suelto!
Route cable without loops and kinks!

Einbau
Montage
Installazione
Instalación
Fitting

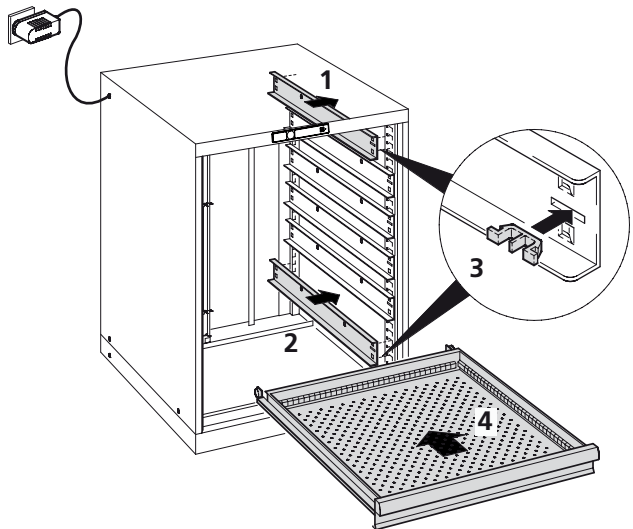

Öffnen
Ouvrir
Apertura
Apertura
Opening

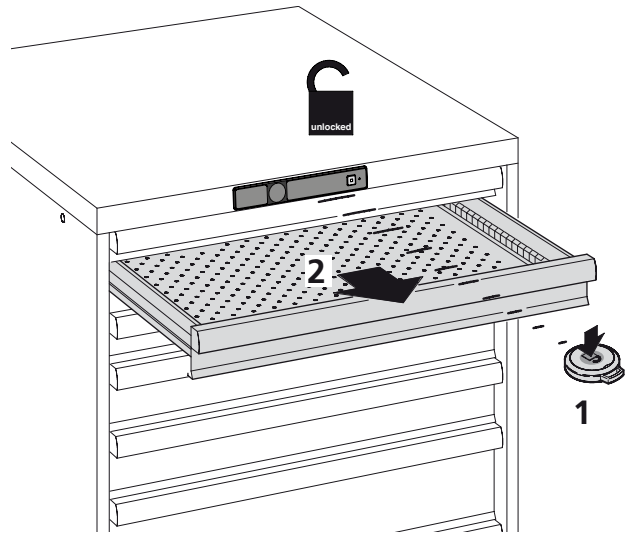

Manuelle Schliessung
Fermeture manuelle
Chiusura manuale
Cierre manual
Manual locking

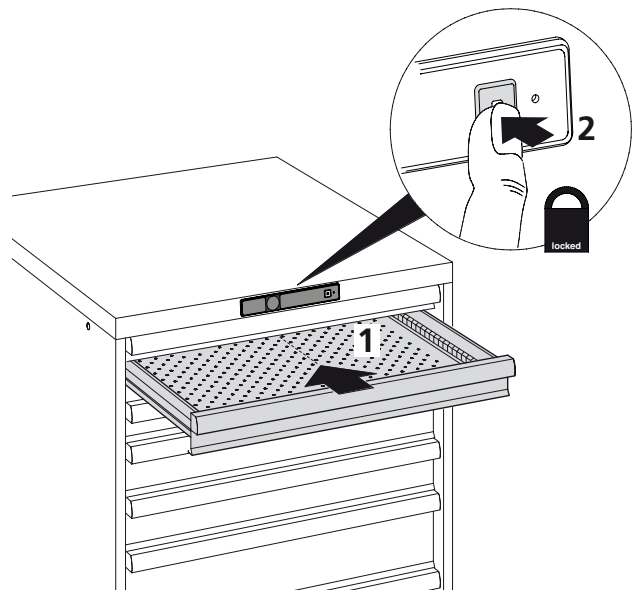

Automatische Schliessung
Fermeture automatique
Chiusura automatica
Cierre automático
Automatic locking

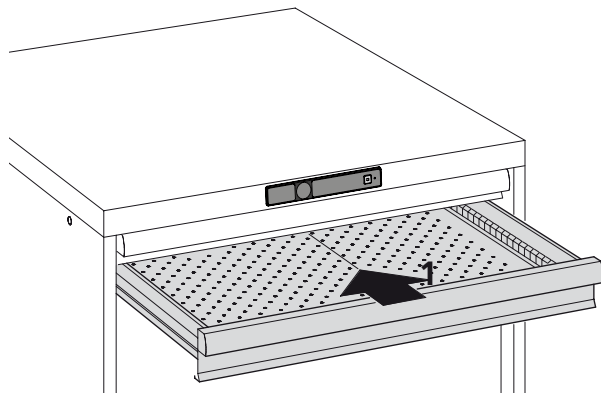

Batteriewechsel
Changement de batterie
Sostituzione della batteria
Cambio de batería
Battery change

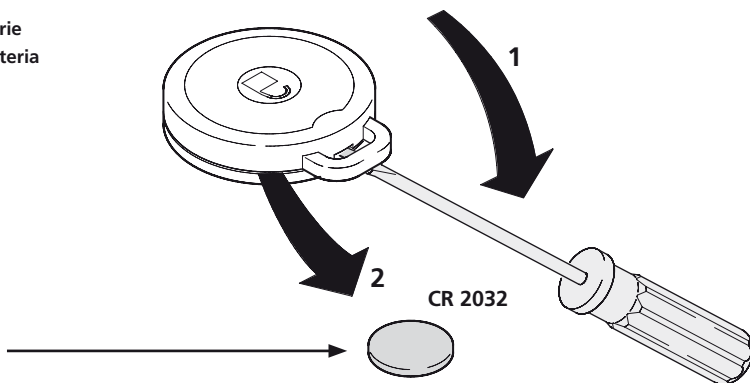

Lista AG
Fabrikstrasse 1
CH-8586 Erlen

Telefon +41 71 649 21 11
Telefax +41 71 649 22 03
info@lista.com
www.lista.com

